

**SPECIFICATIONS FBD 564D**

**DIMENSIONS**

Countertop unit  
 Width: 26 in (660mm)  
 Depth: 32.32 in (822 mm)  
 Height: 41.4 in (1052 mm)  
 (with merchandiser door)

Countertop unit on base cart  
 Width: 26 in (660 mm)  
 Depth: 32.38 in (822 mm)  
 Height: 75.4 in (1915 mm)  
 (with merchandiser door)

**ELECTRICAL** 215 to 245VAC, single phase; 3 wire, 30 amp; uses NEMA # L-630R receptacle  
 Refrigeration Unit: 19,000 BTU, R-404A (60Hz)

**SPACE REQUIRED**  
 Sides or Back: 2 in (51 mm) min  
 Top: 12 in (305 mm)

**WEIGHT**  
 Operating unit: 460 lb (263.1 kg)  
 Base cabinet: 80 lb (36.3 kg)

**SYRUP CONNECTION**  
 Bag-In-Box (BIB)

**MOTORS**  
 Beater: (4) 1/6 HP  
 Fan: 1/4 HP

**WATER**  
 Fresh water, 30 PSI min

**DRAW PERFORMANCE**  
 75°F (25°C) Ambient  
 45% Relative Humidity  
 64oz./minute continuous alternating barrels

**OPTIONAL ACCESSORIES**  
 Base Cabinet w/Casters (Part # 12-2899-0001)  
 Leg Kit (set of four) (Part # 12-2533-0001)

**4 Barrel High Quality Dispenser**



Tall Door



Short Door



Tall Door, Front Lift



Side Open Door is Available in Short or Tall Version



Unit is also available in Water-Cooled

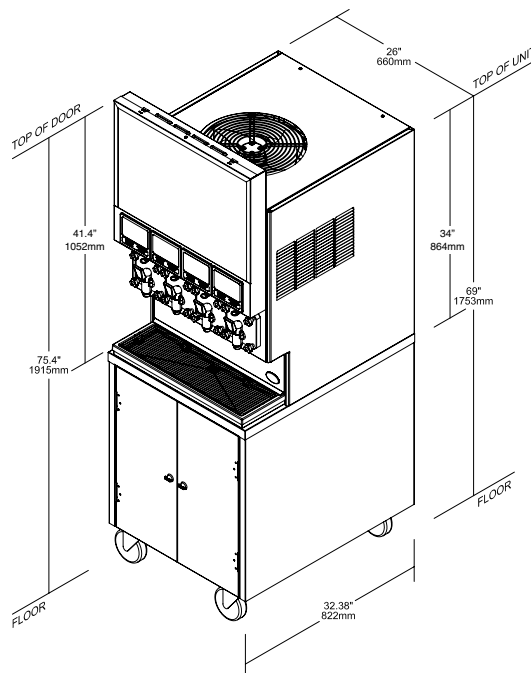

Equipment design and/or specifications may change without notice.

FBD 8161 Interchange Parkway, Suite 115 • San Antonio, TX 78216 • 210.637.2800 • 1.866-323.2777 • Fax: 210.637.2832 • www.fbdfrozen.com  
 Copyright-2007 by FBD Partnership, LP, All Rights Reserved.